

AZV99

PECL/LVDS Oscillator Gain Stage & Buffer with Selectable Enable

FEATURES

- Green and RoHS Compliant / Lead (Pb) Free Packages Available
- Similar Operation as AZ100LVEL16VT except with **LVDS Outputs**
- Operating Range of 3.0V to 5.5V
- Minimizes External Components
- Selectable Enable Polarity and Threshold (CMOS/TTL or PECL)
- Available in a 2x2 or 3x3mm MLP Package
- S-Parameter (.s2p) and IBIS Model Files Available on Arizona Microtek Website
- >2 kV HBM ESD Protection
- Additional ESD Data Available on Arizona Microtek Website

PACKAGE AVAILABILITY

PACKAGE	PART NUMBER	MARKING	NOTES
MLP 8 (2x2x0.75) Green / RoHS Compliant / Lead (Pb) Free	AZV99NG	V1G <Date Code>	1,2
MLP 8 (2x2x0.75) Green / RoHS Compliant / Lead (Pb) Free	AZV99NBG	V8G <Date Code>	1,2
MLP 8 (2x2x0.75) Green / RoHS Compliant / Lead (Pb) Free	AZV99NDG	V2G <Date Code>	1,2
MLP 16 (3x3) Green / RoHS Compliant / Lead (Pb) Free	AZV99LG	AZMG V99 <Date Code>	1,2
MSOP 8 RoHS Compliant / Lead (Pb) Free	AZV99T+	AZ+ V99	1,2,3

- 1 Add R1 at end of part number for 7 inch (1K parts), R2 for 13 inch (2.5K parts) Tape & Reel.
- 2 Date code format: "Y" for year followed by "WW" for week.
- 3 Date Code "YWW" on underside of part.

DESCRIPTION

The AZV99 is a specialized oscillator gain stage with LVDS output buffer including an enable. The enable input (EN) allows continuous oscillator operation by only controlling the Q_{HG}/\bar{Q}_{HG} outputs.

The AZV99 also provides a V_{BB} and 470 Ω internal bias resistors from D to V_{BB} and \bar{D} to V_{BB} . The V_{BB} pin can support 1.5 mA sink/source current. Bypassing V_{BB} to ground with a 0.01 μ F capacitor is recommended.

MLP 16, 3x3 mm Package (L)

The MLP 16 and die versions of the AZV99 provide a selectable enable (EN). Enable polarity and threshold can be selected to accommodate either CMOS/TTL or PECL input levels. See the enable truth table for enable function. If enable pull-up is desired in the CMOS/TTL mode, an external $\leq 20k\Omega$ resistor connecting EN to V_{CC} will override the on-chip pull-down resistor.

Outputs Q/Q each have a selectable on-chip pull-down current source. See the current source truth table for current source functions. External resistors may also be used to increase pull-down current to a maximum of 25mA (includes internal on-chip current source).

AZV99

MLP 8, 2x2 mm Package, NA, NB & ND Options

The MLP 8 NA, NB and ND options of the AZV99 provide a PECL/ECL level enable input (EN). When the EN input is LOW, the Q and Q_{HG}/Q_{HG} outputs pass data from the inputs. When EN is HIGH, the Q output continues to pass data while the Q_{HG} output is forced high and the Q_{HG} output is forced low.

Only the Q output operates with a current source (4 mA) to V_{EE}. This is accomplished by internal bonding of CS-SEL. An external resistor may also be used to increase pull-down current to a maximum of 25mA (includes 4mA on-chip current source).

The AZV99NB and AZV99ND versions operate with a single ended data input (D). The D input is internally bonded directly to the V_{BB} pin bypassing the 470Ω bias resistor.

MSOP 8 Package (T), MLP 8 Package, (N)

The MSOP 8 (T) and MLP 8 (N) versions of the AZV99 provide a CMOS/TTL level enable input (EN). When the EN input is HIGH, the Q and Q_{HG}/Q_{HG} outputs pass data from the inputs. When EN is LOW, the Q output continues to pass data while the Q_{HG} output is forced high and the Q_{HG} output is forced low.

Only the Q output operates with a current source (4 mA) to V_{EE}. This is accomplished by internal bonding of CS-SEL. An external resistor may also be used to increase pull-down current to a maximum of 25mA (includes 4mA on-chip current source).

The MSOP 8 (T) and MLP 8 (N) AZV99 operates with a single ended data input (D). The D input is internally bonded directly to the V_{BB} pin bypassing the 470Ω bias resistor.

NOTE: Specifications in the ECL/PECL tables are valid when thermal equilibrium is established.

PIN DESCRIPTION

PIN	FUNCTION
D/D	Data Inputs
Q/Q	PECL Data Outputs
Q _{HG} /Q _{HG}	LVDS Data Outputs
V _{BB}	Reference Voltage Output
EN-SEL	Selects Enable Logic
EN/EN	Enable Input
CS-SEL	Selects Q and Q Current Source Magnitude
V _{EE}	Negative Supply
V _{CC}	Positive Supply

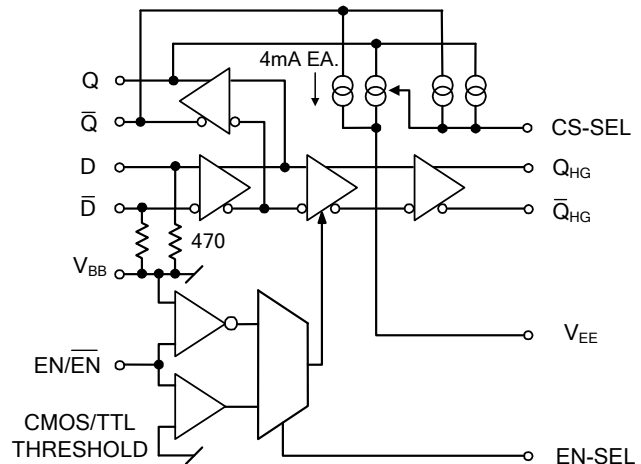

ENABLE TRUTH TABLE

EN-SEL	EN/EN	Q/Q	Q _{HG}	Q _{HG}
NC	PECL Low or NC	Data	Data	Data
NC	PECL High or V _{CC}	Data	High	Low
V _{EE} ¹	CMOS/TTL Low, V _{EE} or NC	Data	High	Low
V _{EE} ¹	CMOS/TTL High or V _{CC} ²	Data	Data	Data

¹ EN-SEL connections must be less than 1Ω.

² An external ≤20kΩ pull-up resistor between EN and V_{CC} ensures a High when the EN pin is not driven.

CURRENT SOURCE TRUTH TABLE

CS-SEL	Q	Q
NC	4mA typ.	4mA typ.
V _{EE} ¹	8mA typ.	8mA typ.
V _{CC} ¹	0	4mA typ.

¹ CS-SEL connections must be less than 1Ω.

Absolute Maximum Ratings are those values beyond which device life may be impaired.

Symbol	Characteristic	Rating	Unit
V _{CC}	Power Supply	0 to +6.0	Vdc
V _I	Input Voltage	0 to +6.0	Vdc
V _{D/D}	D/D Input Voltage	±0.75 with respect to V _{BB}	Vdc
I _{OUT}	Output Current — Continuous Q/Q	25	mA
	— Surge Q/Q	50	
	— Continuous Q _{HG} /Q _{HG}	5	
	— Surge Q _{HG} /Q _{HG}	10	
T _A	Operating Temperature Range	-40 to +85	°C
T _{STG}	Storage Temperature Range	-65 to +150	°C

100K LVPECL DC Characteristics (V_{EE} = GND, V_{CC} = +3.3V)

Symbol	Characteristic	-40°C		0°C		25°C		85°C		Unit
		Min	Max	Min	Max	Min	Max	Min	Max	
V _{OH}	Output HIGH Voltage ^{1,2} Q/Q	2255	2465	2275	2465	2275	2465	2275	2465	mV
V _{OL}	Output LOW Voltage ^{1,2} Q/Q	1375	1745	1400	1680	1400	1680	1400	1680	mV
V _{IH}	Input HIGH Voltage									
	D/D ¹ , EN (EN-SEL open) ¹ EN (EN-SEL tied to V _{EE})	2135 2000	2560 V _{CC}	2135 2000	2560 V _{CC}	2135 2000	2560 V _{CC}	2135 2000	2560 V _{CC}	mV
V _{IL}	Input LOW Voltage									
	D/D ¹ , EN (EN-SEL open) ¹ EN (EN-SEL tied to V _{EE})	1400 GND	1825 800	1400 GND	1825 800	1400 GND	1825 800	1400 GND	1825 800	mV
V _{BB}	Reference Voltage ¹	1910	2050	1910	2050	1910	2050	1910	2050	mV
I _{IL}	Input LOW Current EN ³	0.5		0.5		0.5		0.5		µA
I _{IH}	Input HIGH Current EN ³		150		150		150		150	µA
I _{EE}	Power Supply Current ²		48		48		48		52	mA

1. Voltage levels vary 1:1 with V_{CC}.
2. Specified with CS-SEL open.
3. Specified with EN-SEL open.

100K PECL DC Characteristics (V_{EE} = GND, V_{CC} = +5.0V)

Symbol	Characteristic	-40°C		0°C		25°C		85°C		Unit
		Min	Max	Min	Max	Min	Max	Min	Max	
V _{OH}	Output HIGH Voltage ^{1,2} Q/Q	3955	4165	3975	4165	3975	4165	3975	4165	mV
V _{OL}	Output LOW Voltage ^{1,2} Q/Q	3075	3445	3100	3380	3100	3380	3100	3380	mV
V _{IH}	Input HIGH Voltage									
	D/D ¹ , EN (EN-SEL open) ¹ EN (EN-SEL tied to V _{EE})	3835 2000	4260 V _{CC}	3835 2000	4260 V _{CC}	3835 2000	4260 V _{CC}	3835 2000	4260 V _{CC}	mV
V _{IL}	Input LOW Voltage									
	D/D ¹ , EN (EN-SEL open) ¹ EN (EN-SEL tied to V _{EE})	3100 GND	3525 800	3100 GND	3525 800	3100 GND	3525 800	3100 GND	3525 800	mV
V _{BB}	Reference Voltage ¹	3610	3750	3610	3750	3610	3750	3610	3750	mV
I _{IL}	Input LOW Current EN ³	0.5		0.5		0.5		0.5		µA
I _{IH}	Input HIGH Current EN ³		150		150		150		150	µA
I _{EE}	Power Supply Current ²		48		48		48		52	mA

1. Voltage levels vary 1:1 with V_{CC}.
2. Specified with CS-SEL open.
3. Specified with EN-SEL open.

LVDS DC Characteristics for Q_{HG}/Q_{HG} Outputs¹ (V_{EE} = GND, V_{CC} = +3.0V to +5.5V)

Symbol	Characteristic	-40°C		0°C		25°C		85°C		Unit
		Min	Max	Min	Max	Min	Max	Min	Max	
V _{OH}	Output HIGH Voltage		1600		1600		1600		1600	mV
V _{OL}	Output LOW Voltage	900		900		900		900		mV
V _{OC}	Output Common Mode Voltage ²	1125	1375	1125	1375	1125	1375	1125	1375	mV
ΔV _{OC}	Change in Common Mode Voltage ³	-50	50	-50	50	-50	50	-50	50	mV
V _{OUT}	Single-Ended Output Swing	250	450	250	450	250	450	250	450	mV
V _{DIFF_OUT}	Differential Output Swing	500	900	500	900	500	900	500	900	mV

1. Specified with 100Ω resistor connecting Q_{HG} and Q_{HG} together.
2. Common mode voltage is the center voltage between Q_{HG} and Q_{HG} during a steady state.
3. Change in common mode voltage is the difference between common mode voltages at opposite binary states.

AC Characteristics (V_{EE} = GND, V_{CC} = +3.0V to +5.5V)

Symbol	Characteristic	-40°C			0°C			25°C			85°C			Unit
		Min	Typ	Max	Min	Typ	Max	Min	Typ	Max	Min	Typ	Max	
t _{PLH} / t _{PHL}	Propagation Delay D to Q/Q Outputs ¹ (SE)			400			400			400			430	ps
	D to Q _{HG} /Q _{HG} Outputs ² (SE)			550			550			550			630	
t _{SKEW}	Duty Cycle Skew Q/Q ³ (SE)		5	20		5	20		5	20		5	20	ps
V _{PP} (AC)	Differential Input Swing ⁴	80		1000	80		1000	80		1000	80		1000	mV
t _r / t _f	Output Rise/Fall Times (20% - 80%)													ps
	Q/Q ¹ Q _{HG} /Q _{HG} ²	100		260	100		260	100		260	100		260	

1. Specified with CS-SEL connected to V_{EE} and Q/Q with AC coupled 50Ω loads.
2. Specified with 100Ω resistor connecting Q_{HG} and Q_{HG} together.
3. Duty cycle skew is the difference between a t_{PLH} and t_{PHL} propagation delay through a device.
4. The peak-to-peak differential input swing is the range for which AC parameters guaranteed. V_D and V_D must remain within the range of ±750 mV with respect to V_{BB}.

AC PP INPUT

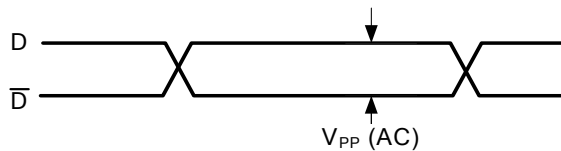

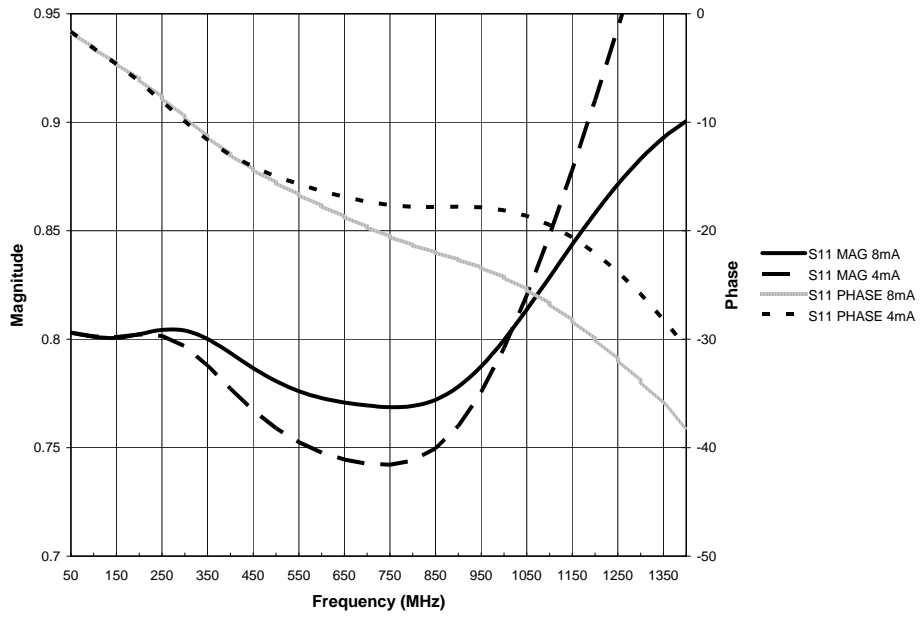

S11, D to Q, 50 Ω AC load on Q

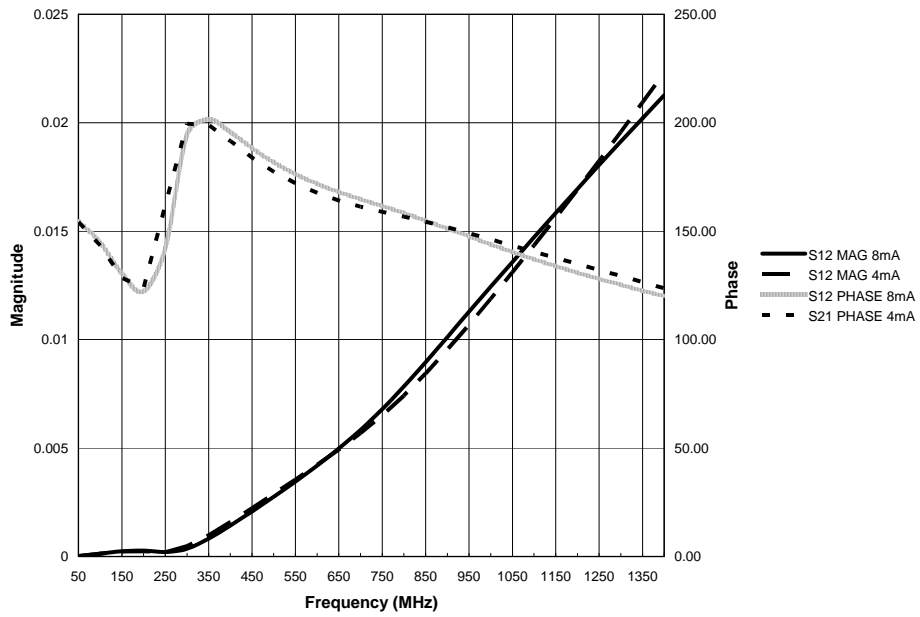

S12, D to Q, 50 Ω AC load on Q

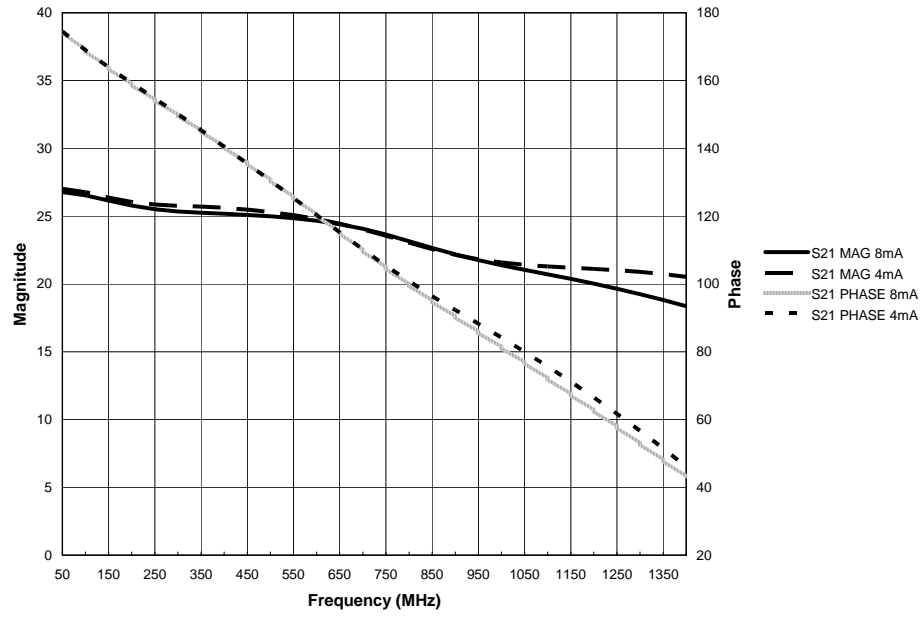

S21, D to Q, 50 Ω AC load on Q

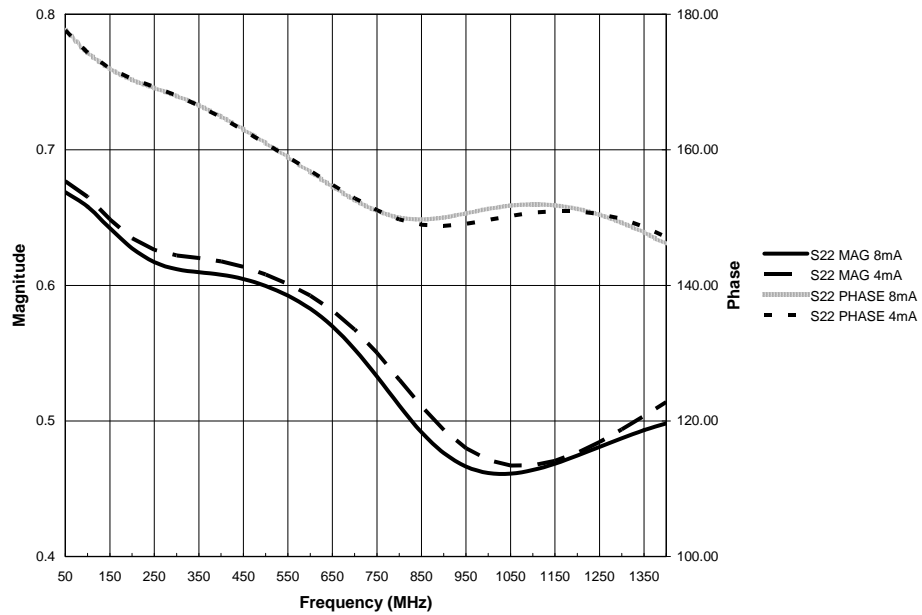

S22, D to Q, 50 Ω AC load on Q

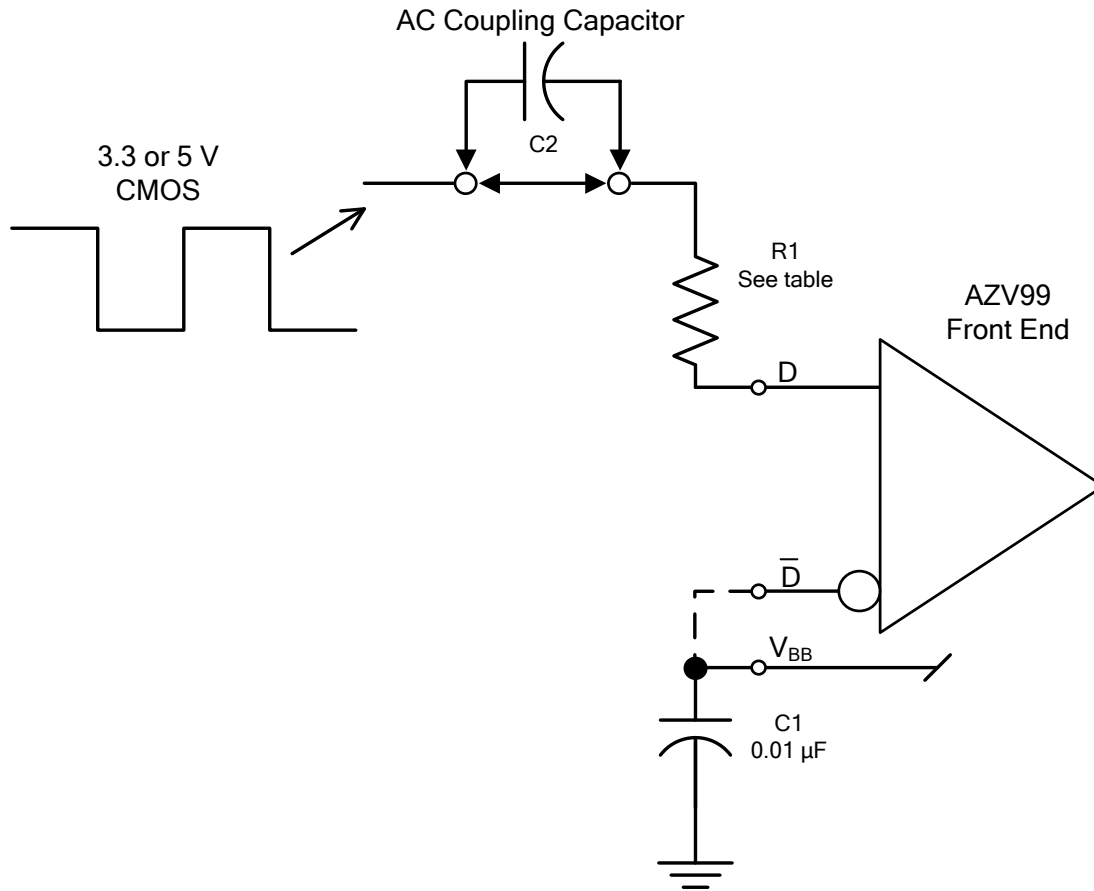

Application Circuit for CMOS Inputs

Input Type	R1 ¹	
	AC Coupled (C2 in circuit)	DC Coupled (C2 shorted)
3.3 V CMOS	1.1 k Ω	2.0 k Ω
5 V CMOS	1.6 k Ω	3.3 k Ω

¹ R1 should be chosen so that the input swing on the D input with respect to D is in the range of ± 80 to ± 1000 mV, per the AC Characteristics table and the D input is $< \pm 750$ mV with respect to V_{BB}.

Recommended Component Values for CMOS Single Ended Inputs

**LOGIC DIAGRAMS AND PINOUTS FOR
AZV99NA, AZV99NB, AZV99ND**

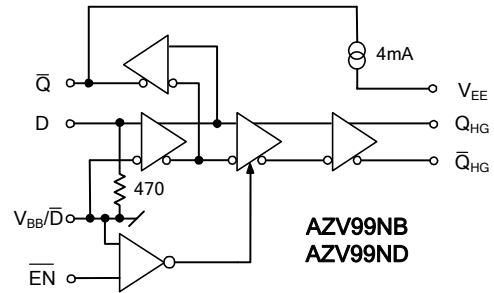
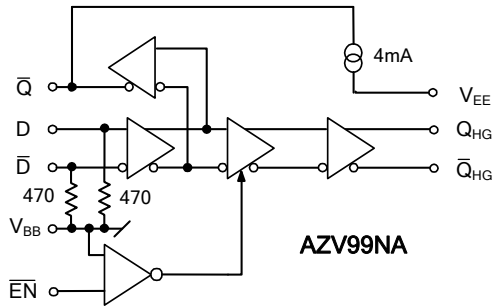

**EN operation follows PECL functionality. See the
Timing Diagram.**

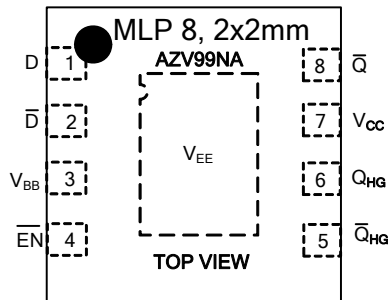

**Bottom Center Pad is the V_{EE}
return.**

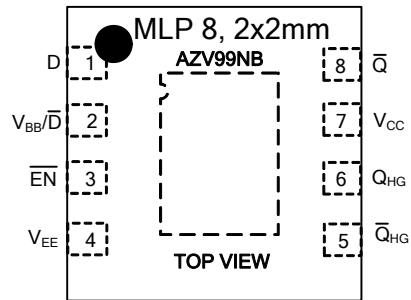

**Bottom Center Pad may be left open
or tied to V_{EE} . Pin 4 is the V_{EE}
return.**

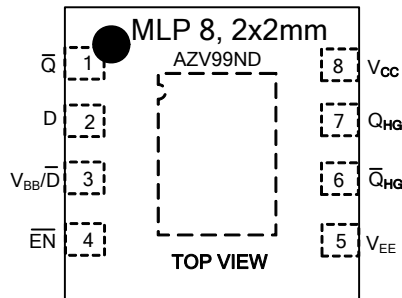

**Bottom Center Pad may be left open
or tied to V_{EE} . Pin 5 is the V_{EE}
return.**

**LOGIC DIAGRAM AND PINOUTS FOR
AZV99T, AZV99N**

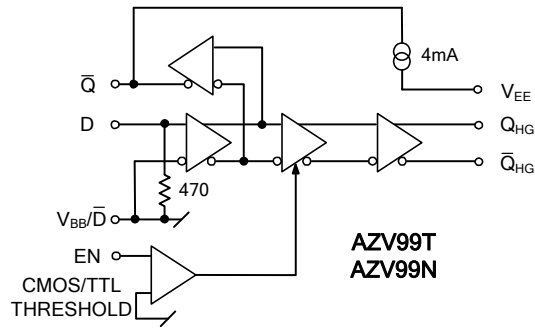

EN follows CMOS/TTL functionality. See the Timing Diagram.

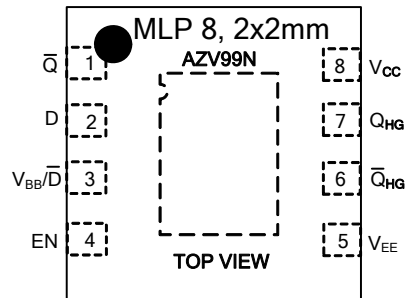
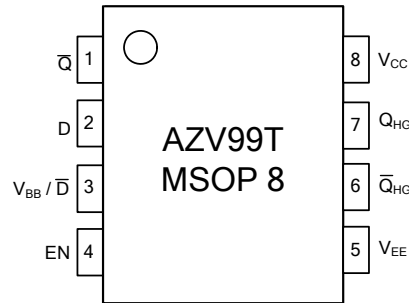

Bottom Center Pad may be left open or tied to V_{EE} . Pin 5 is the V_{EE} return.

**PACKAGE DIAGRAM
MLP 16**

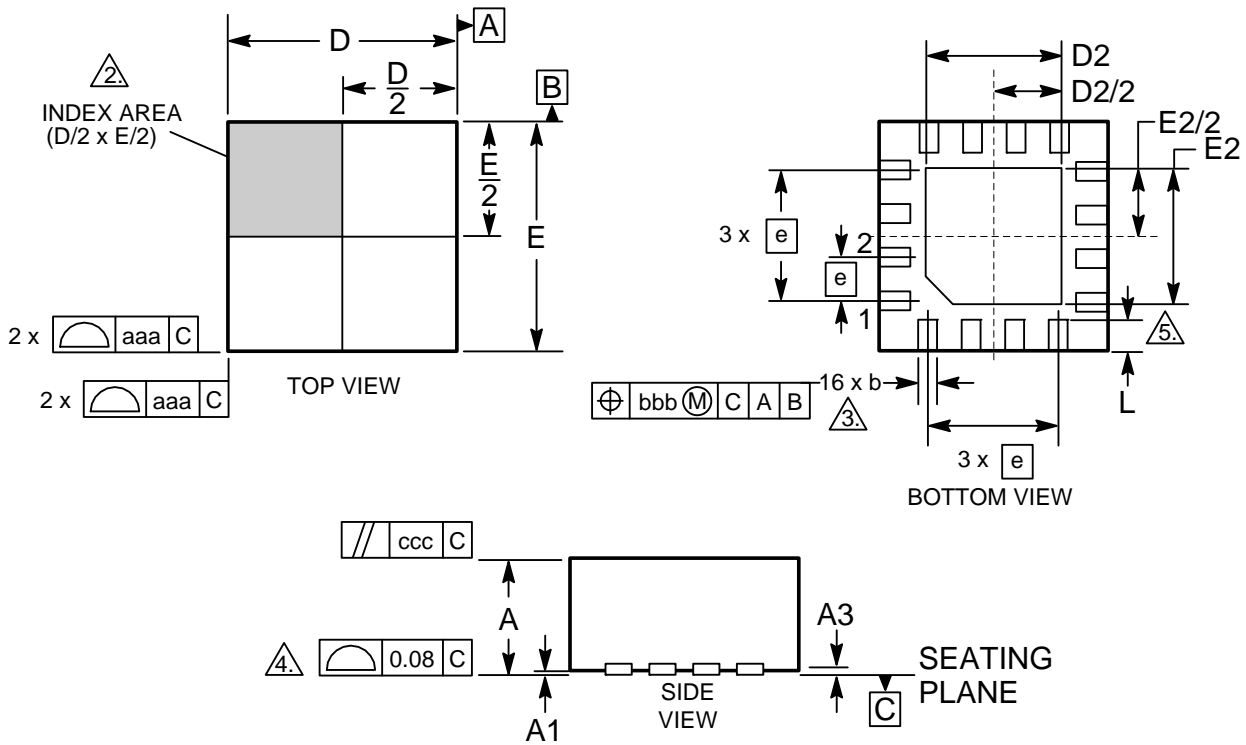

- NOTES:**
1. DIMENSIONING AND TOLERANCING CONFORM TO ASME T14-1994.
 - ② THE TERMINAL #1 AND PAD NUMBERING CONVENTION SHALL CONFORM TO JESD 95-1 SPP-012.
 - ③ DIMENSION b APPLIES TO METALLIZED PAD AND IS MEASURED BETWEEN 0.25 AND 0.30 mm FROM PAD TIP.
 - ④ COPLANARITY APPLIES TO THE EXPOSED PADS AS WELL AS THE TERMINALS.
 - ⑤ INSIDE CORNERS OF METALLIZED PAD MAY BE SQUARE OR ROUNDED

DIM	MILLIMETERS	
	MIN	MAX
A	0.80	1.00
A1	0.00	0.05
A3	0.25 REF	
b	0.18	0.30
D	2.90	3.10
D2	0.25	1.95
E	2.90	3.10
E2	0.25	1.95
e	0.50 BSC	
L	0.30	0.50
aaa	0.25	
bbb	0.10	
ccc	0.10	

PACKAGE DIAGRAM
MLP 8 2x2mm

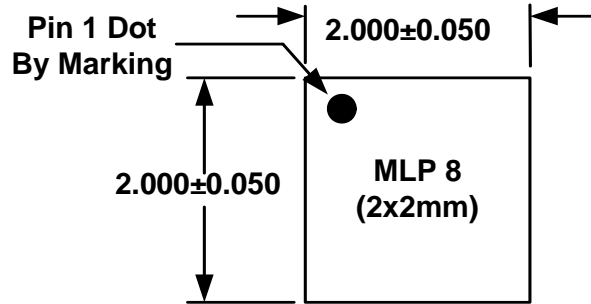

TOP VIEW

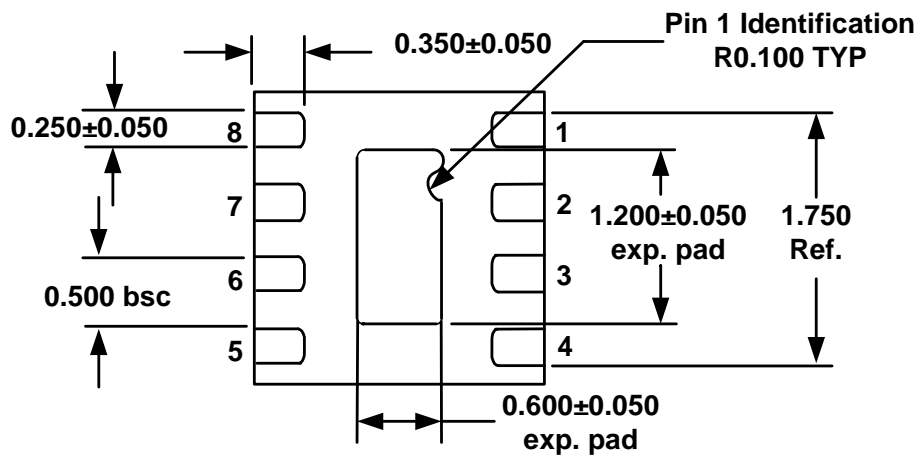

BOTTOM VIEW

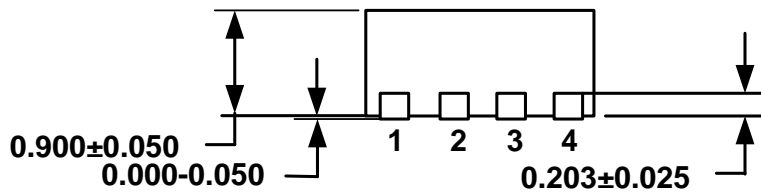

SIDE VIEW

Note: All dimensions are in mm

**PACKAGE DIAGRAM
MSOP 8**

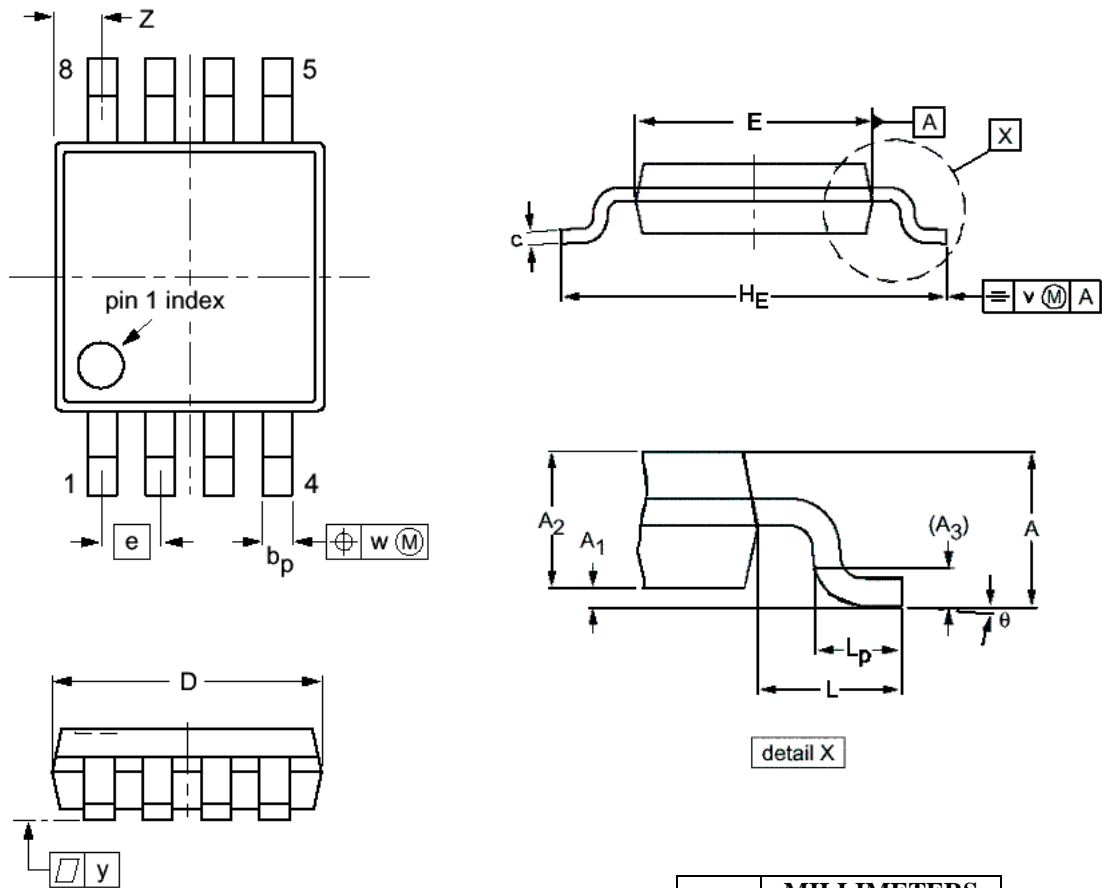

- NOTES:
1. DIMENSIONS D AND E DO NOT INCLUDE MOLD PROTRUSION.
 2. MAXIMUM MOLD PROTRUSION FOR D IS 0.15mm.
 3. MAXIMUM MOLD PROTRUSION FOR E IS 0.25mm.

DIM	MILLIMETERS	
	MIN	MAX
A		1.10
A ₁	0.05	0.15
A ₂	0.80	0.95
A ₃	0.25	
b _p	0.25	0.45
c	0.15	0.28
D	2.90	3.10
E	2.90	3.10
e	0.65	
H _E	4.70	5.10
L	0.94	
L _p	0.40	0.70
v	0.10	
w	0.10	
y	0.10	
Z	0.35	0.70
θ	0°	6°

Arizona Microtek, Inc. reserves the right to change circuitry and specifications at any time without prior notice. Arizona Microtek, Inc. makes no warranty, representation or guarantee regarding the suitability of its products for any particular purpose, nor does Arizona Microtek, Inc. assume any liability arising out of the application or use of any product or circuit and specifically disclaims any and all liability, including without limitation special, consequential or incidental damages. Arizona Microtek, Inc. does not convey any license rights nor the rights of others. Arizona Microtek, Inc. products are not designed, intended or authorized for use as components in systems intended to support or sustain life, or for any other application in which the failure of the Arizona Microtek, Inc. product could create a situation where personal injury or death may occur. Should Buyer purchase or use Arizona Microtek, Inc. products for any such unintended or unauthorized application, Buyer shall indemnify and hold Arizona Microtek, Inc. and its officers, employees, subsidiaries, affiliates, and distributors harmless against all claims, costs, damages, and expenses, and reasonable attorney fees arising out of, directly or indirectly, any claim of personal injury or death associated with such unintended or unauthorized use, even if such claim alleges that Arizona Microtek, Inc. was negligent regarding the design or manufacture of the part.