

AZP92

ECL/PECL $\div 1$, $\div 2$ Clock Generation Chip with Selectable Enable

FEATURES

- Green and RoHS Compliant / Lead (Pb) Free Package Available
- 3.0V to 5.5V Operation
- Selectable Divide Ratio
- Selectable Enable Polarity and Threshold (CMOS/TTL or PECL)
- Selectable Input Biasing
- High Bandwidth, 1.5+ GHz ($\div 1$), 3+ GHz ($\div 2$)
- -145 dBc/Hz ($\div 1$), -151 dBc/Hz ($\div 2$) Typical Noise Floor
- Available in a MLP 8 (2x2) Package
- S Parameter and IBIS Model Files Available on Arizona Microtek Website
- >2 kV HBM ESD Protection
- Additional ESD Data Available on Arizona Microtek Website

PACKAGE AVAILABILITY

PACKAGE	PART NO.	MARKING	NOTES
MLP 8 (2x2) Green / RoHS Compliant / Lead (Pb) Free	AZP92NAG	P1G <Date Code>	1,2

- 1 Add R1 at end of part number for 7 inch (1K parts), R2 for 13 inch (2.5K parts) Tape & Reel.
- 2 Date code format: "Y" for year followed by "WW" for week.

DESCRIPTION

The AZP92 is a specialized $\div 1$ or $\div 2$ clock generation part including an enable/reset function. The divide ratio is selected with the DIV-SEL pin/pad. When DIV-SEL is open (NC), the AZP92 functions as a standard receiver. If DIV-SEL is connected to V_{EE} , it functions as a $\div 2$ divider.

A selectable enable is provided which also functions as a reset when the $\div 2$ mode is selected. Enable (EN) functionality is selected with the EN-SEL pin/pad which has three valid states: open (NC), V_{EE} , or connected to V_{EE} via a 20k Ω resistor. Leaving EN-SEL open or connecting it to V_{EE} will select the EN pin/pad to function as an active high CMOS/TTL enable. When EN-SEL is open, an internal 75k Ω pull-up resistor is selected which enables the outputs whenever EN is left open. When EN-SEL is connected to V_{EE} , an internal 75k Ω pull-down resistor is selected which disables the outputs whenever EN is left open.

Connecting the EN-SEL to V_{EE} with a 20k Ω resistor will select the EN pin/pad to function as an active low PECL/ECL enable with an internal 75k Ω pull-down resistor. In this mode, outputs are enabled when EN is left open (NC). This default logic condition can be overridden by connecting the EN to V_{CC} with an external resistor of $\leq 20k\Omega$. Refer to the enable truth table on the next page for detailed operation.

MLP 8, 2x2 mm Package (AZP92NA)

The AZP92NA provides a V_{BB} with an 1880 Ω internal bias resistor from D to V_{BB} . This feature allows AC coupling with minimal external components. The V_{BB} pin supports 1.5mA sink/source current and should be bypassed to ground or V_{CC} with a 0.01 μ F capacitor.

NOTE: The specifications in the ECL/PECL tables are valid when thermal equilibrium has been established.

SIGNAL DESCRIPTION

PIN/PAD	FUNCTION
D	Data Input
Q/Q	Data Outputs
V _{BB} /D	Reference Voltage Output
EN	Enable/Reset Input
EN-SEL	Enable Logic Select
DIV-SEL	Divide Ratio Select
V _{EE}	Negative Supply
V _{CC}	Positive Supply

ENABLE TRUTH TABLE

EN-SEL	EN	Q	Q
NC	CMOS Low or V _{EE}	Low	High
NC	CMOS High, V _{CC} or NC	Data	Data
V _{EE}	CMOS Low, V _{EE} or NC	Low	High
V _{EE}	CMOS High or V _{CC}	Data	Data
20kΩ to V _{EE}	PECL Low, V _{EE} or NC	Data	Data
20kΩ to V _{EE}	PECL High or V _{CC}	Low	High

DIVIDE TRUTH TABLE

DIV-SEL	DIVIDE RATIO
NC	÷1
V _{EE} ¹	÷2

¹ DIV-SEL connection must be ≤1Ω.

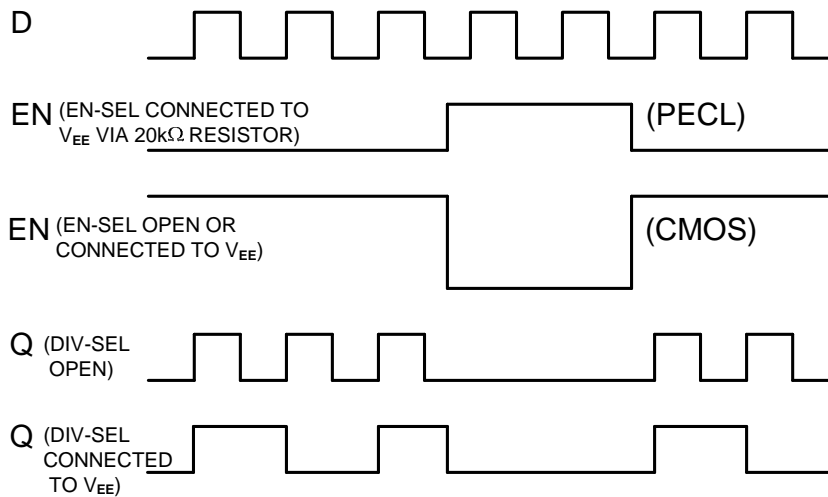

TIMING DIAGRAM

AZP92

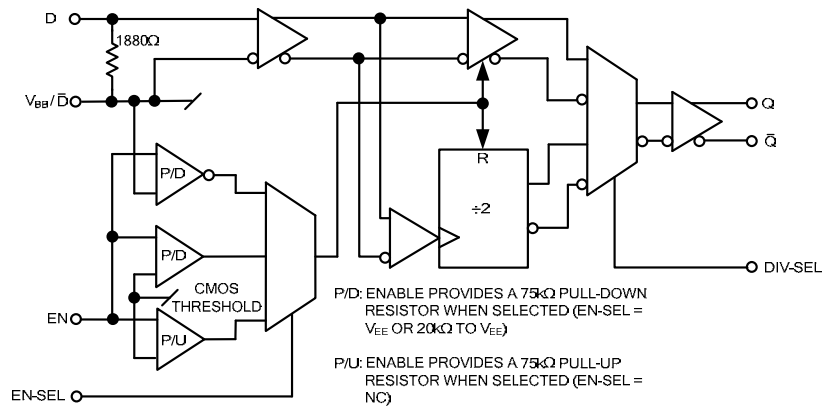
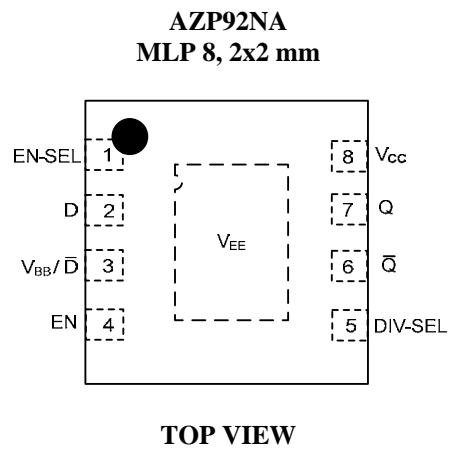

Absolute Maximum Ratings are those values beyond which device life may be impaired.

Symbol	Characteristic	Rating	Unit
V _{CC}	PECL Power Supply (V _{EE} = 0V)	0 to +6.0	Vdc
V _I	PECL Input Voltage (V _{EE} = 0V)	0 to +6.0	Vdc
V _{EE}	ECL Power Supply (V _{CC} = 0V)	-6.0 to 0	Vdc
V _I	ECL Input Voltage (V _{CC} = 0V)	-6.0 to 0	Vdc
I _{HGOUT}	Output Current — Continuous — Surge	50 100	mA
T _A	Operating Temperature Range	-40 to +85	°C
T _{STG}	Storage Temperature Range	-65 to +150	°C

100K ECL DC Characteristics (V_{EE} = -3.0V to -5.5V, V_{CC} = GND)

Symbol	Characteristic	-40°C		0°C		25°C		85°C		Unit
		Min	Max	Min	Max	Min	Max	Min	Max	
V _{OH}	Output HIGH Voltage ¹	-1085	-880	-1025	-880	-1025	-880	-1025	-880	mV
V _{OL}	Output LOW Voltage ¹	-1900	-1555	-1900	-1620	-1900	-1620	-1900	-1620	mV
V _{IH}	Input HIGH Voltage D/D, EN (ECL) ² EN (CMOS) ³	-1165 V _{EE} +2000	-390 V _{CC}	-1165 V _{EE} +2000	-390 V _{CC}	-1165 V _{EE} +2000	-390 V _{CC}	-1165 V _{EE} +2000	-390 V _{CC}	mV
V _{IL}	Input LOW Voltage D/D, EN (ECL) ² EN (CMOS) ³	-2250 V _{EE}	-1475 V _{EE} + 800	-2250 V _{EE}	-1475 V _{EE} + 800	-2250 V _{EE}	-1475 V _{EE} + 800	-2250 V _{EE}	-1475 V _{EE} + 800	mV
V _{BB}	Reference Voltage	-1390	-1250	-1390	-1250	-1390	-1250	-1390	-1250	mV
I _{IH}	Input HIGH Current EN		150		150		150		150	µA
I _{IL}	Input LOW Current EN (ECL) ² EN (CMOS) ³	0.5 -150		0.5 -150		0.5 -150		0.5 -150		µA
I _{EE}	Power Supply Current ⁴		31		31		31		34	mA

1. Specified with outputs terminated through 50Ω resistors to V_{CC} - 2V.
2. EN-SEL connected to V_{EE} through a 20kΩ resistor.
3. EN-SEL connected V_{EE} or left open (NC).
4. DIV-SEL left open (NC).

100K LVPECL DC Characteristics (V_{EE} = GND, V_{CC} = +3.3V)

Symbol	Characteristic	-40°C		0°C		25°C		85°C		Unit
		Min	Max	Min	Max	Min	Max	Min	Max	
V _{OH}	Output HIGH Voltage ^{1,2}	2215	2420	2275	2420	2275	2420	2275	2420	mV
V _{OL}	Output LOW Voltage ^{1,2}	1400	1745	1400	1680	1400	1680	1400	1680	mV
V _{IH}	Input HIGH Voltage ¹ D/D, EN (PECL) ³ EN (CMOS) ⁴	2135 2000	2910 V _{CC}	2135 2000	2910 V _{CC}	2135 2000	2910 V _{CC}	2135 2000	2910 V _{CC}	mV
V _{IL}	Input LOW Voltage ¹ D/D, EN (PECL) ³ EN (CMOS) ⁴	1050 GND	1825 800	1050 GND	1825 800	1050 GND	1825 800	1050 GND	1825 800	mV
V _{BB}	Reference Voltage ¹	1910	2050	1910	2050	1910	2050	1910	2050	mV
I _{IH}	Input HIGH Current EN		150		150		150		150	µA
I _{IL}	Input LOW Current EN (PECL) ³ EN (CMOS) ⁴	0.5 -150		0.5 -150		0.5 -150		0.5 -150		µA
I _{EE}	Power Supply Current ⁵		31		31		31		34	mA

1. For supply voltages other than 3.3V, use the ECL table values and ADD supply voltage value.
2. Specified with outputs terminated through 50Ω resistors to V_{CC} - 2V.
3. EN-SEL connected to V_{EE} through a 20kΩ resistor.
4. EN-SEL connected V_{EE} or left open (NC).
5. DIV-SEL left open (NC).

100K PECL DC Characteristics ($V_{EE} = \text{GND}$, $V_{CC} = +5.0\text{V}$)

Symbol	Characteristic	-40°C		0°C		25°C		85°C		Unit
		Min	Max	Min	Max	Min	Max	Min	Max	
V_{OH}	Output HIGH Voltage ^{1,2}	3915	4120	3975	4120	3975	4120	3975	4120	mV
V_{OL}	Output LOW Voltage ^{1,2}	3100	3445	3100	3380	3100	3380	3100	3380	mV
V_{IH}	Input HIGH Voltage ¹	3835	4610	3835	4610	3835	4610	3835	4610	mV
	D/D, EN (PECL) ³ EN (CMOS) ⁴	2000	V_{CC}	2000	V_{CC}	2000	V_{CC}	2000	V_{CC}	
V_{IL}	Input LOW Voltage ¹	2750	3525	2750	3525	2750	3525	2750	3525	mV
	D/D, EN (PECL) ³ EN (CMOS) ⁴	GND	800	GND	800	GND	800	GND	800	
V_{BB}	Reference Voltage ¹	3610	3750	3610	3750	3610	3750	3610	3750	mV
I_{IH}	Input HIGH Current EN		150		150		150		150	μA
I_{IL}	Input LOW Current									μA
	EN (PECL) ³ EN (CMOS) ⁴	0.5 -150		0.5 -150		0.5 -150		0.5 -150		
I_{EE}	Power Supply Current ⁵		31		31		31		34	mA

1. For supply voltages other than 5.0V, use the ECL table values and ADD supply voltage value.
2. Specified with outputs terminated through 50Ω resistors to $V_{CC} - 2\text{V}$.
3. EN-SEL connected to V_{EE} through a 20kΩ resistor.
4. EN-SEL connected V_{EE} or left open (NC).
5. DIV-SEL left open (NC).

AC Characteristics ($V_{EE} = -3.0\text{V}$ to -5.5V ; $V_{CC} = \text{GND}$ or $V_{EE} = \text{GND}$; $V_{CC} = +3.0\text{V}$ to $+5.5\text{V}$)

Symbol	Characteristic	-40°C			0°C			25°C			85°C			Unit
		Min	Typ	Max	Min	Typ	Max	Min	Typ	Max	Min	Typ	Max	
t_{PLH} / t_{PHL}	Propagation Delay			450			450			450			450	ps
	D to Q/Q Outputs ¹ (SE) EN to Q/Q Outputs ¹			600			600			600			600	
t_{SKEW}	Duty Cycle Skew ² (SE)		5	20		5	20		5	20		5	20	ps
$V_{PP}(\text{AC})$	Input Swing ³			1000			1000			1000			1000	mV
	Differential (D/D) Single Ended (D) ⁴	150 300		2000	150 300		2000	150 300		2000	150 300		2000	
t_r / t_f	Output Rise/Fall ¹ (20% - 80%)	80		200	80		200	80		200	80		200	ps

1. Specified with outputs terminated through 50Ω resistors to $V_{CC} - 2\text{V}$.
2. Duty cycle skew is the difference between a t_{PLH} and t_{PHL} propagation delay through a device.
3. The peak-to-peak input swing is the range for which AC parameters are guaranteed.
4. Range valid for AC coupled signals only.

AC PP INPUT (Differential)

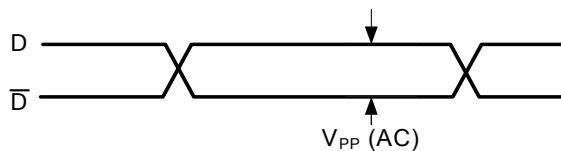

Typical Large Signal Output Swing, Q/Q

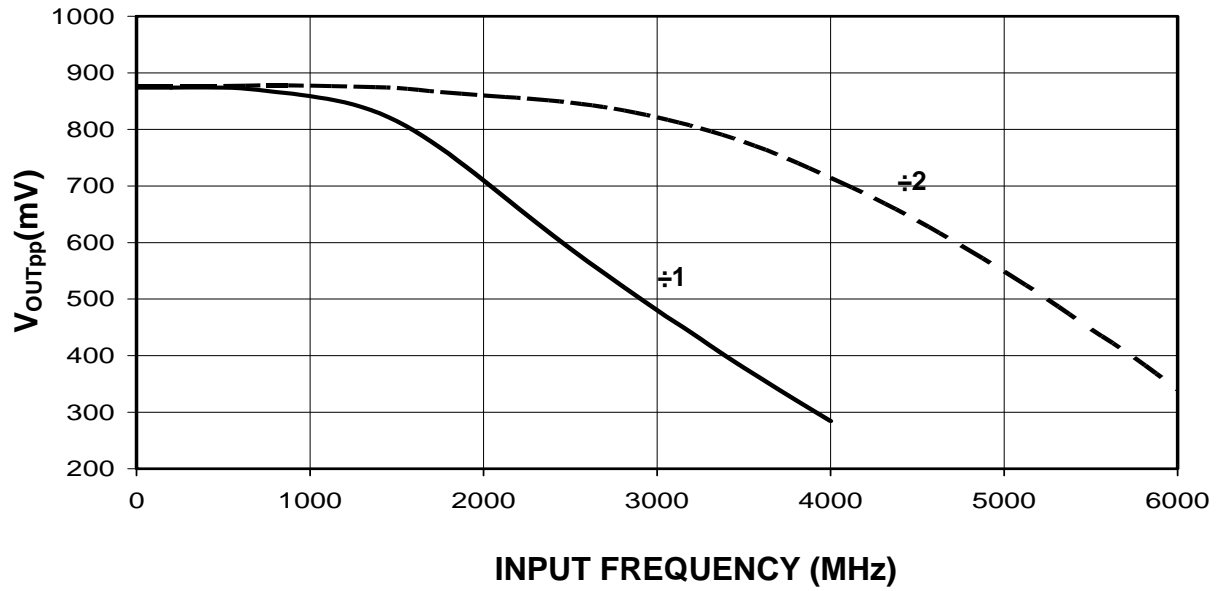

Measured with 750mv D input, Q/Q each terminated to V_{CC}-2V via 50 Ω resistors.

PACKAGE DIAGRAM
MLP 8 2x2mm

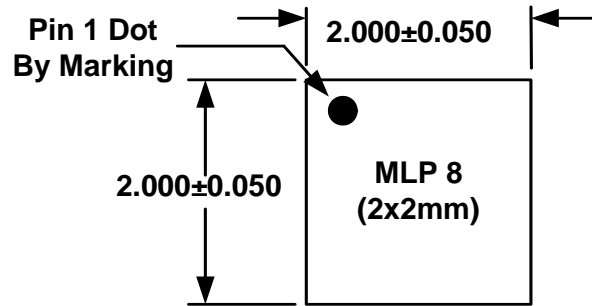

TOP VIEW

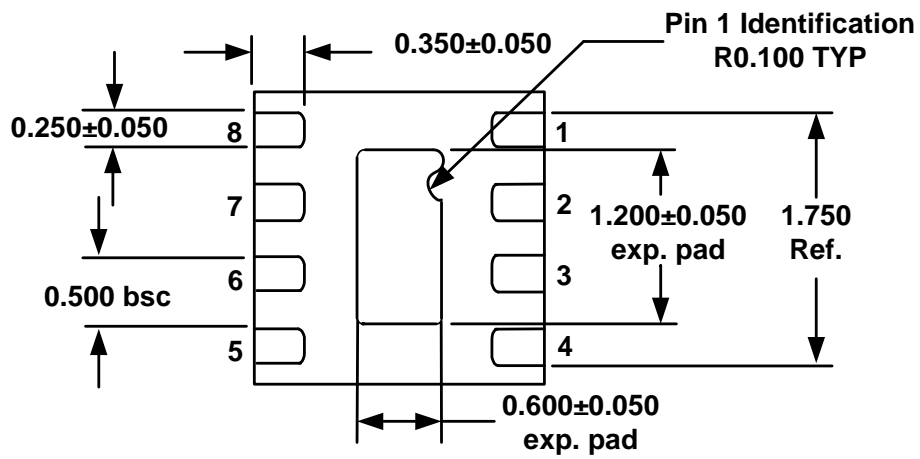

BOTTOM VIEW

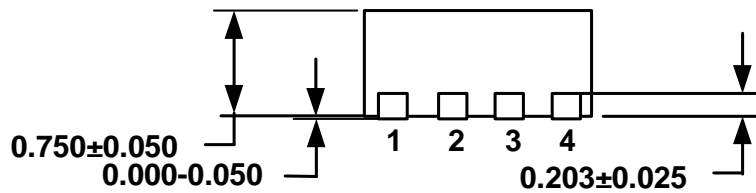

SIDE VIEW

Note: All dimensions are in mm

TAPE & REEL PACKAGING
MLP 8 2x2mm

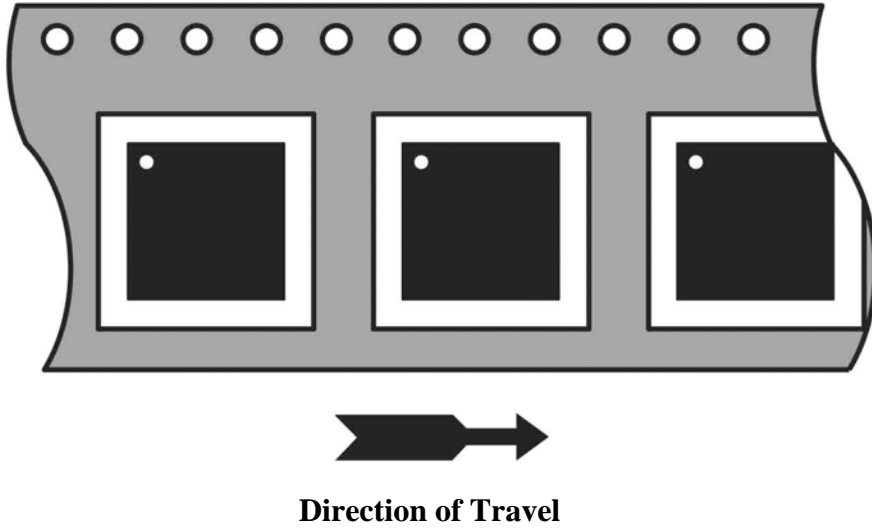

Package	Suffix	Reel Diameter	Quantity	Carrier Tape Width	Carrier Tape Pitch
MLP 8 (2x2mm)	R1	7"	1000	8mm	4mm
	R2	13"	2500	8mm	4mm

Arizona Microtek, Inc. reserves the right to change circuitry and specifications at any time without prior notice. Arizona Microtek, Inc. makes no warranty, representation or guarantee regarding the suitability of its products for any particular purpose, nor does Arizona Microtek, Inc. assume any liability arising out of the application or use of any product or circuit and specifically disclaims any and all liability, including without limitation special, consequential or incidental damages. Arizona Microtek, Inc. does not convey any license rights nor the rights of others. Arizona Microtek, Inc. products are not designed, intended or authorized for use as components in systems intended to support or sustain life, or for any other application in which the failure of the Arizona Microtek, Inc. product could create a situation where personal injury or death may occur. Should Buyer purchase or use Arizona Microtek, Inc. products for any such unintended or unauthorized application, Buyer shall indemnify and hold Arizona Microtek, Inc. and its officers, employees, subsidiaries, affiliates, and distributors harmless against all claims, costs, damages, and expenses, and reasonable attorney fees arising out of, directly or indirectly, any claim of personal injury or death associated with such unintended or unauthorized use, even if such claim alleges that Arizona Microtek, Inc. was negligent regarding the design or manufacture of the part.